

SAMOSA MAKING MACHINE

Model SAM-25HT

本機は、全自動のサモサ成形機(モデル: SAM-25HT)であり、モデルHT-30とモデルSAM-25とで構成されています。

HT-30では、ミキサーで混合攪拌された生地(小麦粉・卵など)をホッパーに送り、加熱されたドラムの表面に焼き付けます。熱源は電気、内蔵された温度センサーにより、ドラム表面の温度を一定に保ちます。一方、SAM-25は、HT-30で焼かれた皮を一定の寸法に切断し、その上加熱調理された具(肉・野菜など)を定量充填し、自動的に包み込まれます。成形されたサモサは、取り出しコンベアー上に、一列に並んで出てきます。

This (Model: SAM-25HT) is a full-automatic samosa making machine. The machine consists of two units: HT-30 and SAM-25. The HT-30 continuously produces the baked thin pastry skin in the form of belt, and send the skin to the SAM-25. While, the SAM-25 firstly cuts the sent skin into the specified length to make wrappers, then deposits the cooked stuff, including meats, vegetables, etc., on the wrapper, after that wraps the stuff through five steps, as shown in right, finally pushes the wrapped products (Samosa) on to the outlet conveyer.

*For the wrapper, raw wheat-flour pastry skin also can be used.



Samosa



Bean-stuffed crepe
あん入りクレープ



Samosa
三角春巻



Crepe ice クレープアイス

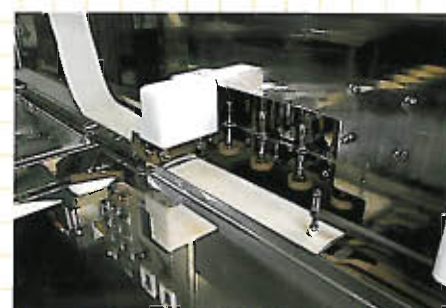

Skin-supply section

皮供給部



Stuff-depositing section

定量充填部

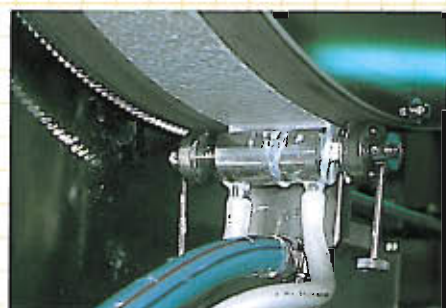

Skin nozzle

皮ノズル

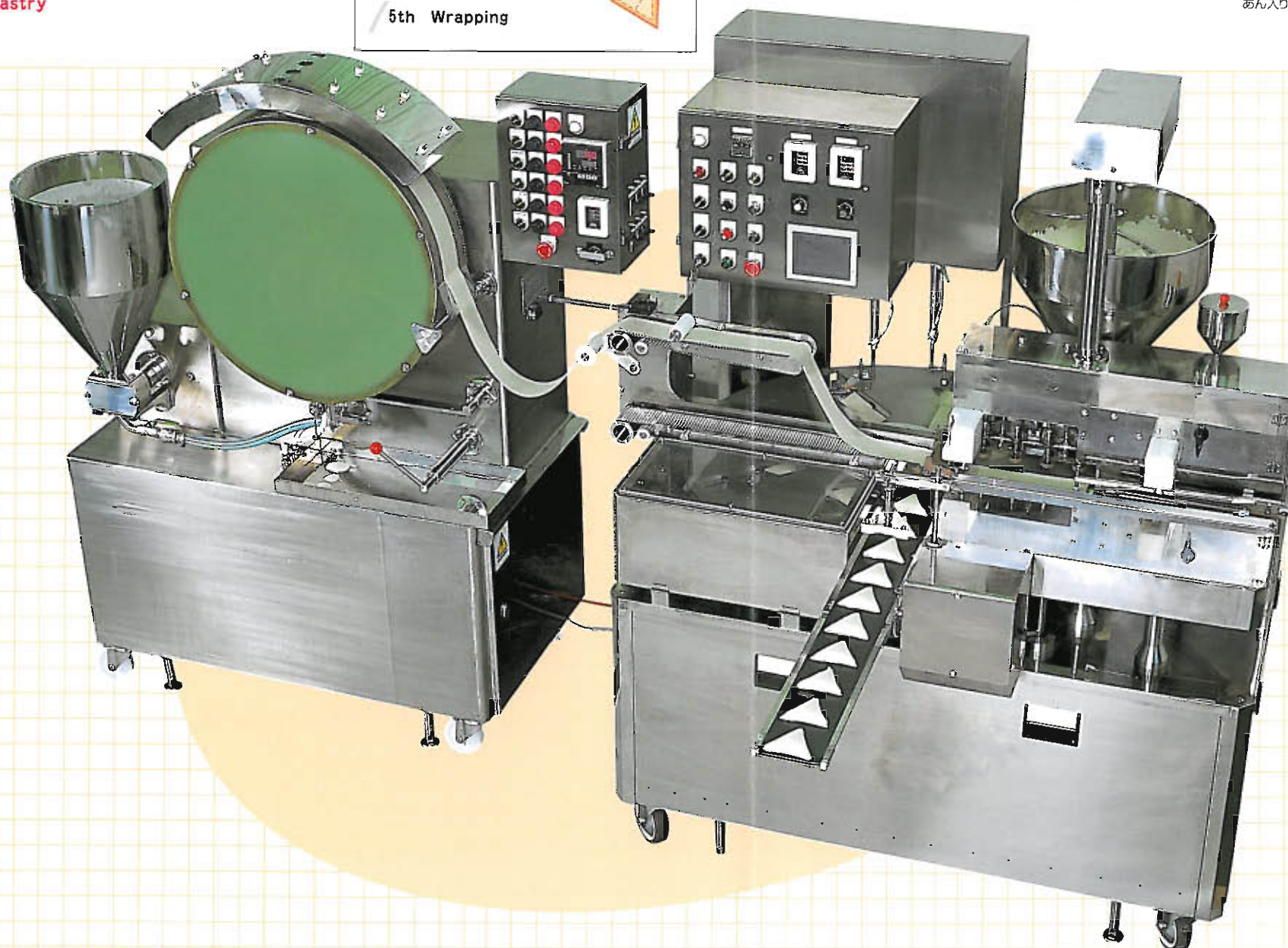

Applied machine



半自動サモサ成形機
SEMI-AUTOMATIC SAMOSA
MAKING MACHINE

Model: SAM-7

- Production capacity : 5 Ps/Minutes
- Products weight : 18 g ~ 50 g / Pc
Note) The weight is not adjustable.
One weight must be taken at time of order
- Products size : 60×60×60~90×90×90

サモサ(三角包)成形機

SAMOSA MAKING MACHINE

Model SAM-25HT

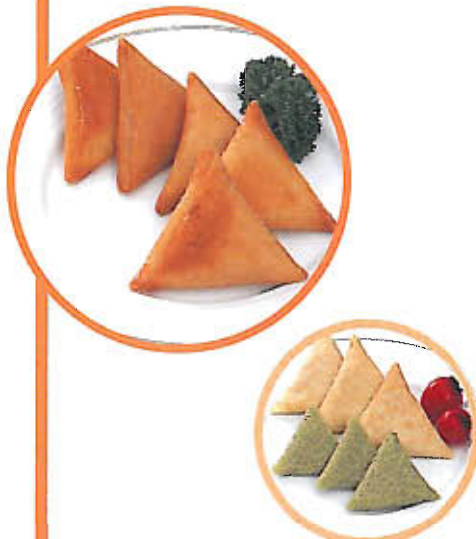
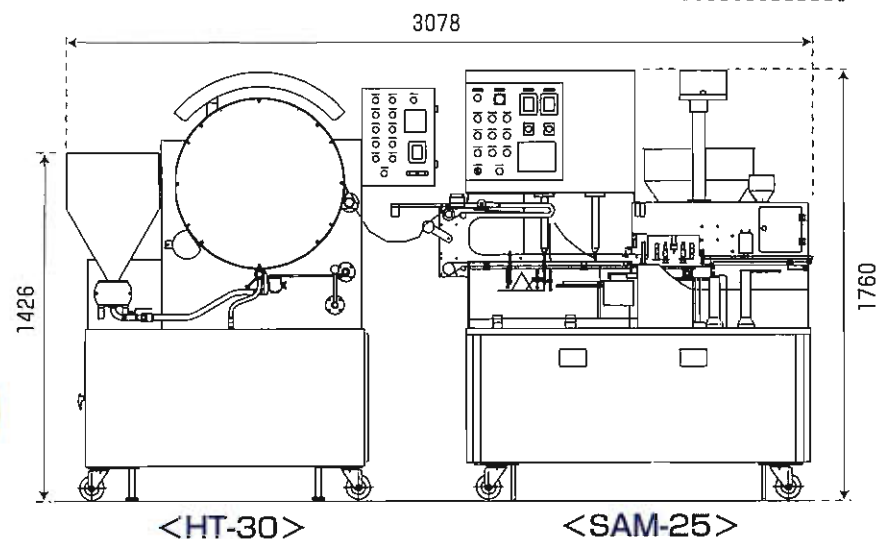
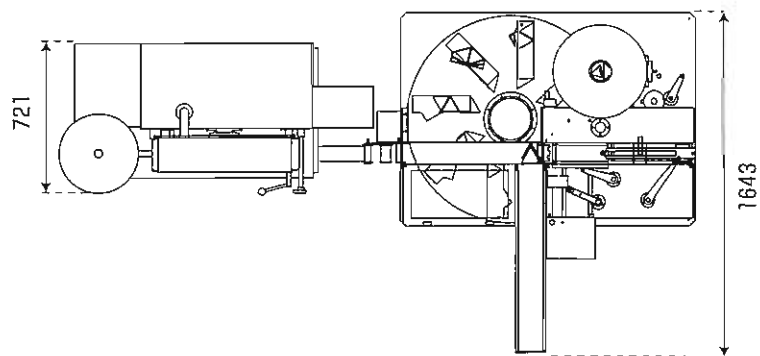

Specification

Samosa Making Line, Model: SAM-25HT (HT-30, SAM-25)	HT-30	SAM-25
Production capacity: 1,500Pcs/Hr	Max. 6m/min.	25Pcs/min.
Products size (This must be decided at the time of order.)		
Length of one side: 50mm-80mm		
Weight : 25g-50g		
Power requirement : 23.88KW, 3P, 200V	18.88KW	5.00KW
Machine dimension : 3,078x1,643x1,760H	1,340x880x1,760H	1,738x1,643x1,760H
Machine weight : 1,680kg	420kg	750kg

用途: サモサ、三角春巻、八つ橋、クレープアイス、生菓子、餡入クレープ
初めて機械化された包み方ですので新製品の開発に応用できます。

Application: Samosa, Traiangle spring roll, Crepe Ice, Bean-stuffed crepe, Other confectinery.
This wrapping method is mechanized for the first time, so it can be applied for developing new foods.



大英技研株式会社

本社 〒661-0021 兵庫県尼崎市名神町1丁目5番6号
TEL:06-6426-0101 FAX:06-6426-2525

東京営業所 〒133-0053 東京都江戸川区北篠崎1-1-24
TEL:03-5243-2101 FAX:03-5243-2103

URL: <http://www.daiei-giken.co.jp/>
E-mail : sales@daiei-giken.co.jp

DAIEI ENGINEERING CO.,LTD.

1-5-6, Meishin-cho, Amagasaki-City, HYOGO
661-00221, JAPAN

Tel +81-6-6426-0101 Fax +81-6-6426-2525

Daiei

SAMOSA MAKING MACHINE

サモサ成形機 / 三角包成形機



DAIEI ENGINEERING CO.,LTD.